

STRAIGHT FLANGE CABLE JACK-CRIMP TYPE
CABLE 2.6/50

Issue : 0629 B

Page

SERIES: BNC 1 / 2

PEN 90-0130-014

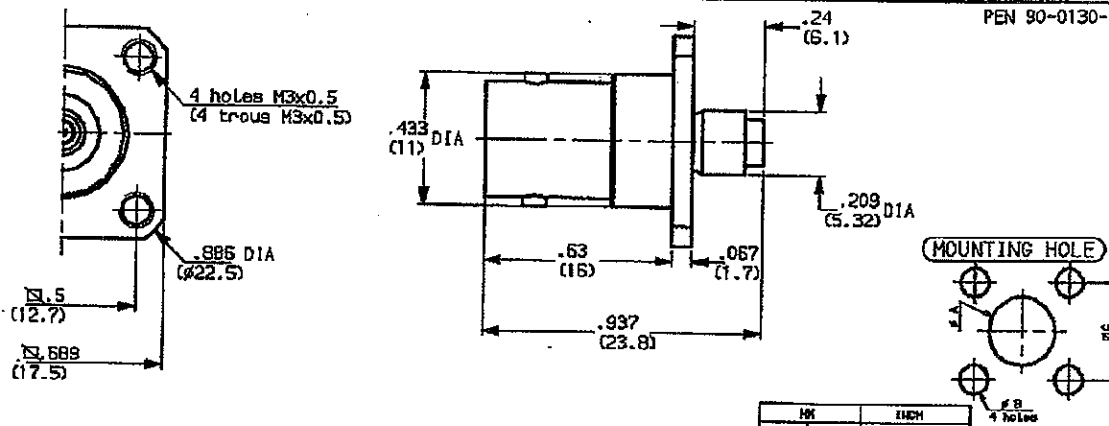

WEIGHT oz (g)

Cable: RG316 KX22A

CHARACTERISTICS

NOMINAL IMPEDANCE	50 Ω
FREQUENCY RANGE	0-4 GHz
TEMPERATURE RATING	-65/+165 °C
VSWR	1.3 Max
RF INSERTION LOSS	.115 fF dB Max1
VOLTAGE RATING	250 Vrms Max1
DIELECTRIC WITHSTANDING VOLTAGE	750 Vrms mini
INSULATION RESISTANCE	5000 M Ω mini
HERMETIC SEAL	NA cc/s Atm.cm3/s
LEAKAGE (pressurized only)	NA psi MPa
-	-
-	-

STANDARDISATION

CABLE RETENTION	9 lb mini 40 N
CENTER CONTACT RETENTION	
Axial force - mating end	8.075 lb mini 27 N
Axial force - opposite end	8.075 lb mini 27 N
Torque (Min)	NA inch.oz cm.N
RECOMMENDED TORQUES	
Mating	NA inch.lb cm.N
Panel nut	NA inch.lb cm.N
Clamp nut	NA inch.lb cm.N

CONSTRUCTION

CONNECTOR PARTS	MATERIALS	FINISH
BODY	BRASS	NICKEL
OUTER CONTACT	BRASS	NICKEL
CENTER CONTACT	BERYLLIUM COPPER	GOLD
INSULATORS	PTFE	-
ADAPTER SLEEVE	BRASS	NICKEL
-	-	-
-	-	-
-	-	-
-	-	-

ISSUE	REVISION No	DESCRIPTION	BY	DATE
-	-	-	-	-
-	-	-	-	-
-	-	-	-	-
-	-	-	-	-

Initiated on 21-AUG-90

The information given here is subject to change without notice. Design changes may be in order to improve the product.



Superseded on 30-04-91

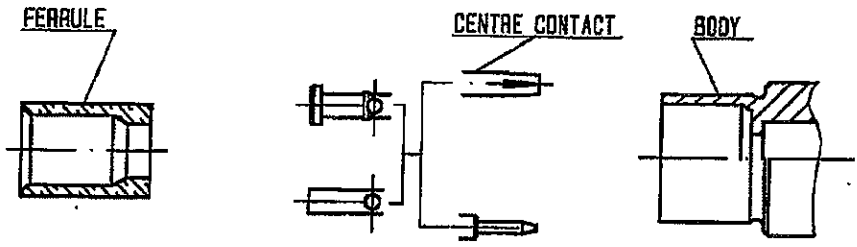

① Strip the cable .
-
-
-

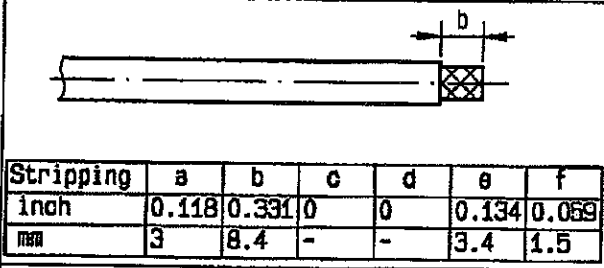

② Slide on the ferrule until it bottoms against the jacket .
Fold back braid and trim off surplus braid .
Trim the inner conductor as shown .
-
-
-

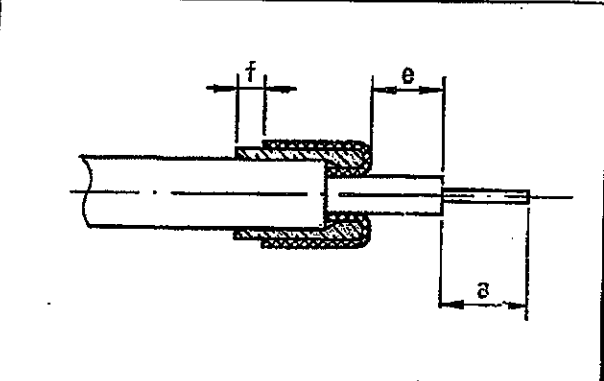

③ Slide on the centre contact until it bottoms against cable dielectric .
Crimp centre contact , crimping tool R 282 223 000 (Hex. : .068) or crimping tool R 282 293 000 (M22520/5-01) + dies R 282 235 009 (M22520/5-09)
-
-
-

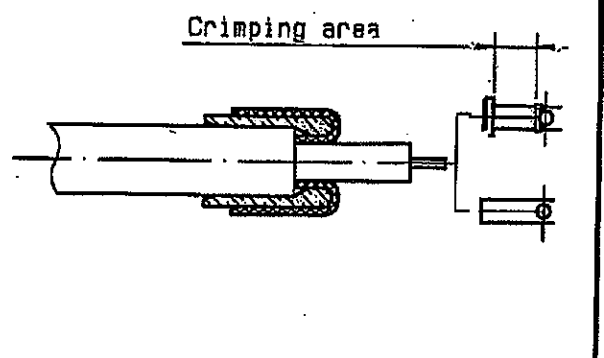

④ Slide sub-assembly into the connector body .
Crimp the body , crimping tool R 282 211 000 (Hex. : .178) or crimping tool R 282 293 000 (M22520/5-01) + dies R 282 235 009 (M22520/5-09)

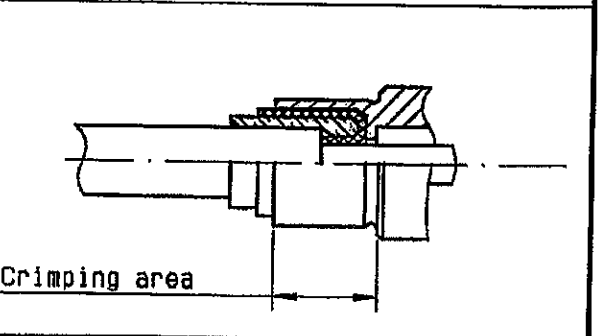

This information is given as an indication . In the continual goal to improve our products , we reserve the right to make any modifications judged necessary .

43 44